

Bob Coecke & Aleks Kissinger

Universities of Oxford and Nijmegen

no-broadcasting in process theories

Bob Coecke & Aleks Kissinger

Universities of Oxford and Nijmegen

no-broadcasting in process theories



...the full story in <15 mins

cf. H. Barnum, J. Barrett, M. Leifer and A. Wilce (2007) *Generalized no-broadcasting theorem*. PRL. arXiv:0707.0620

Bob Coecke & Aleks Kissinger

Universities of Oxford and Nijmegen

no-broadcasting in process theories



...including all math from scratch

cf. H. Barnum, J. Barrett, M. Leifer and A. Wilce (2007) *Generalized no-broadcasting theorem*. PRL. arXiv:0707.0620

Bob Coecke & Aleks Kissinger

Picturing Quantum Processes.

Cambridge University Press, 2016. (920pp)

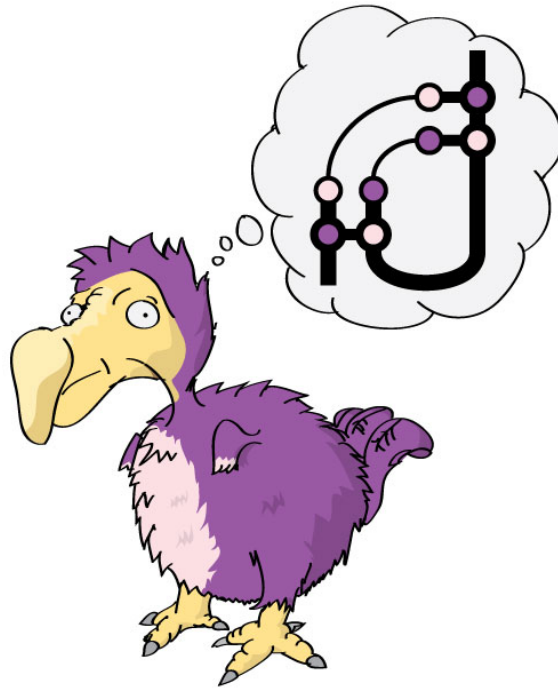

Bob Coecke & Aleks Kissinger

*Categorical quantum mechanics I:
causal quantum processes.*

arXiv:1510.05468

*Categorical quantum mechanics II:
classical-quantum interaction.*

arXiv:1605.08617

*Categorical quantum mechanics III:
(strong) complementarity.*

arXiv:XXX (next couple of weeks)

Diagram := boxes with ins/outs wired together

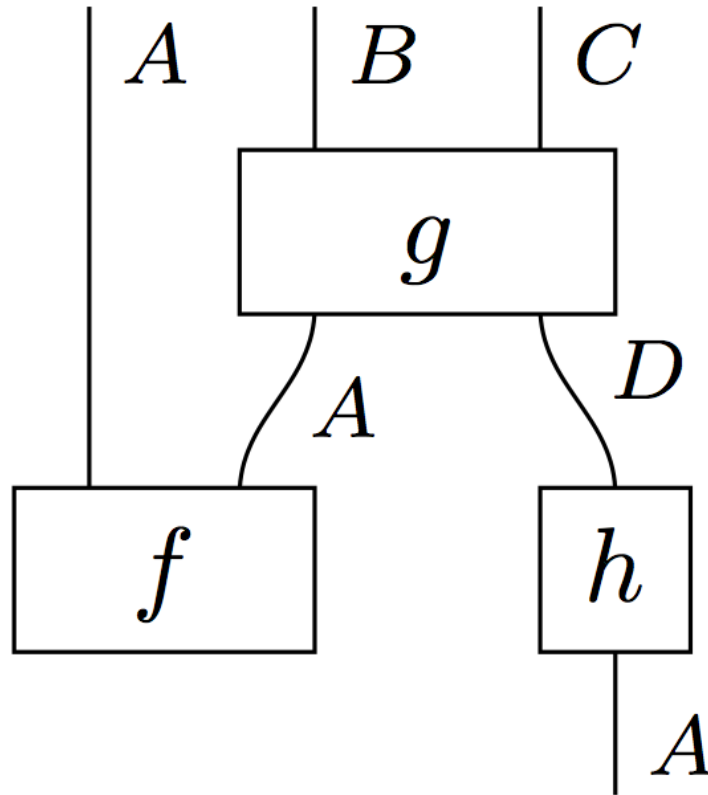

Process theory := interpretation of diagrams

Process theory := interpretation of diagrams

- assign to each wire a **system**
- assign to each box a **process**

Process theory := interpretation of diagrams

- assign to each wire a **system**
- assign to each box a **process**
- **interprets ‘wiring together’**

Process theory := interpretation of diagrams

- assign to each wire a **system**
- assign to each box a **process**
- **interprets ‘wiring together’** e.g.:
 - as actual physical wires,

Process theory := interpretation of diagrams

- assign to each wire a **system**
- assign to each box a **process**
- **interprets ‘wiring together’** e.g.:
 - as actual physical wires, or,
 - via decomposing in \circ and \otimes .

Special processes:

- **State** :=

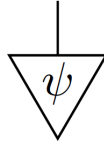

- **Effect / Test** :=

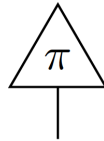

Special processes:

- **State** :=

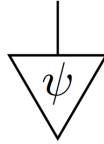

- **Effect / Test** :=

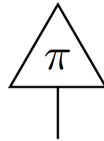

- **Number** :=



Special processes:

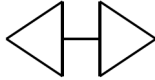
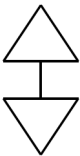
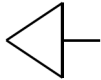

String diagram := ins and outs on equal footing

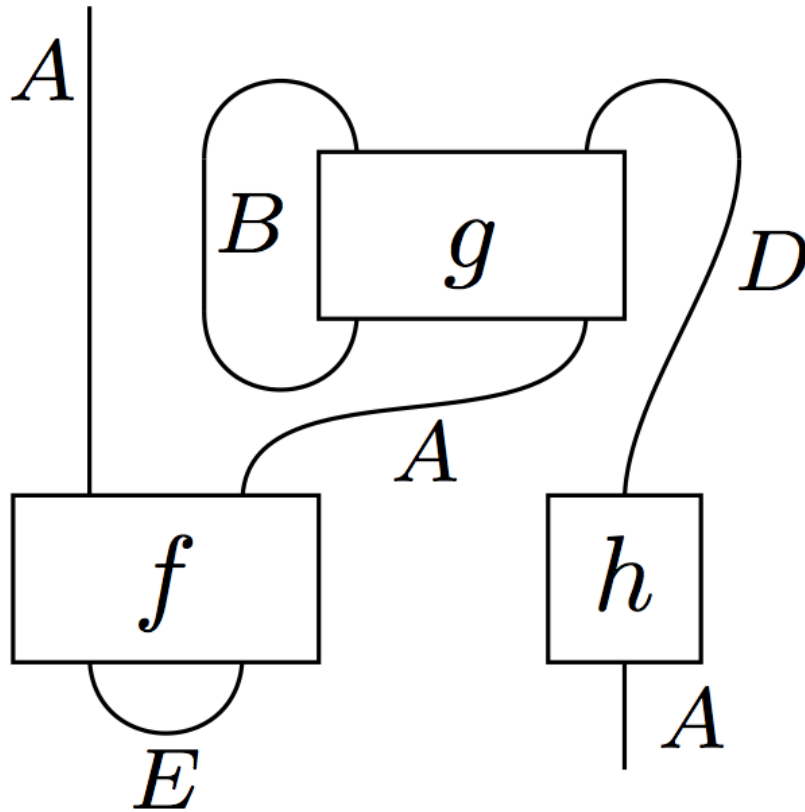

– teleportation –

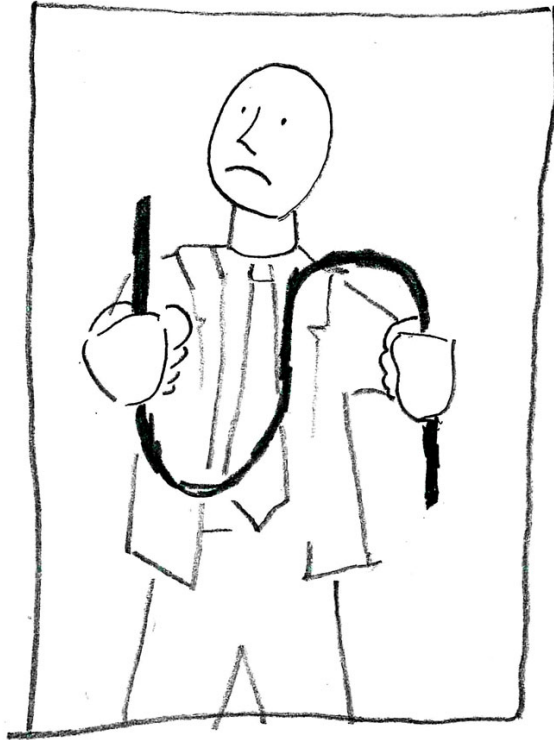

– transpose –

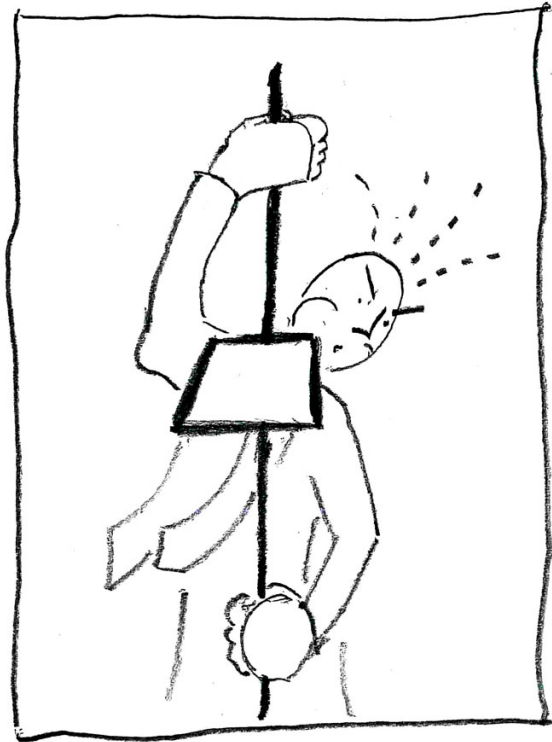
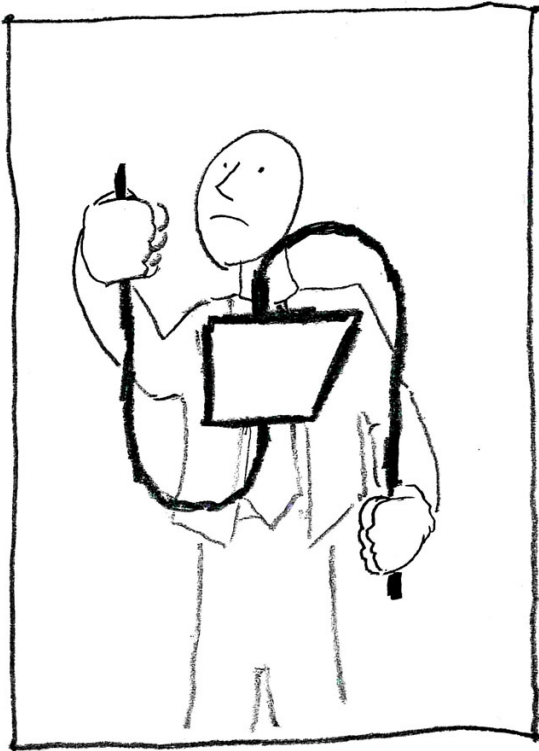

Adjoint := **H-reflection**

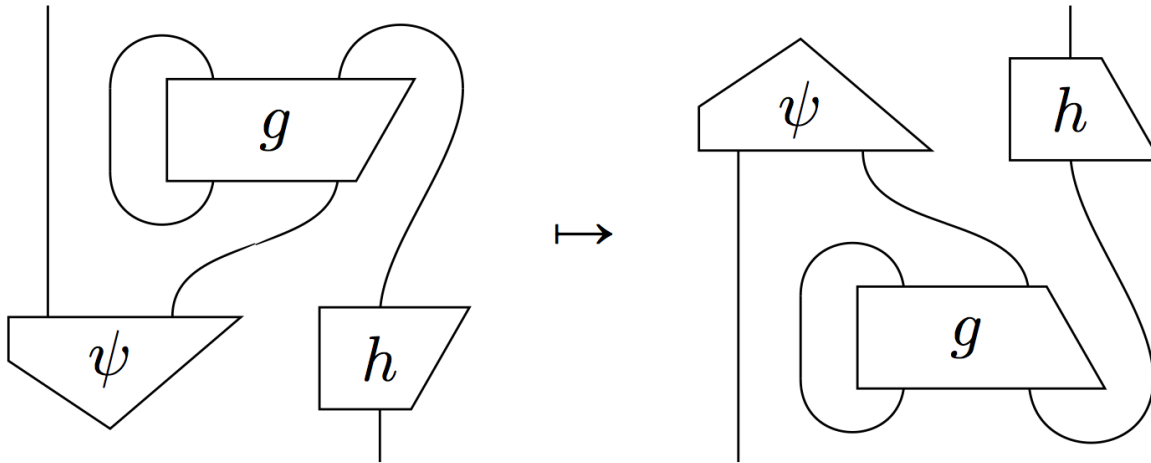

...conjugate

...conjugate := V-reflection

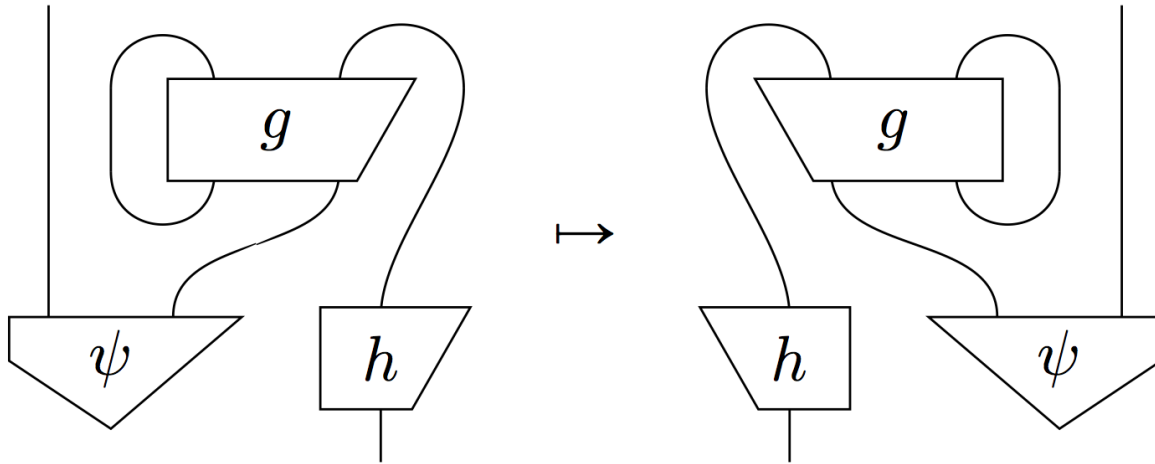

Main idea:

$$\frac{\text{classical system}}{\text{quantum system}} = \frac{\text{single wire}}{\text{double wire}}$$

Pure quantum process :=

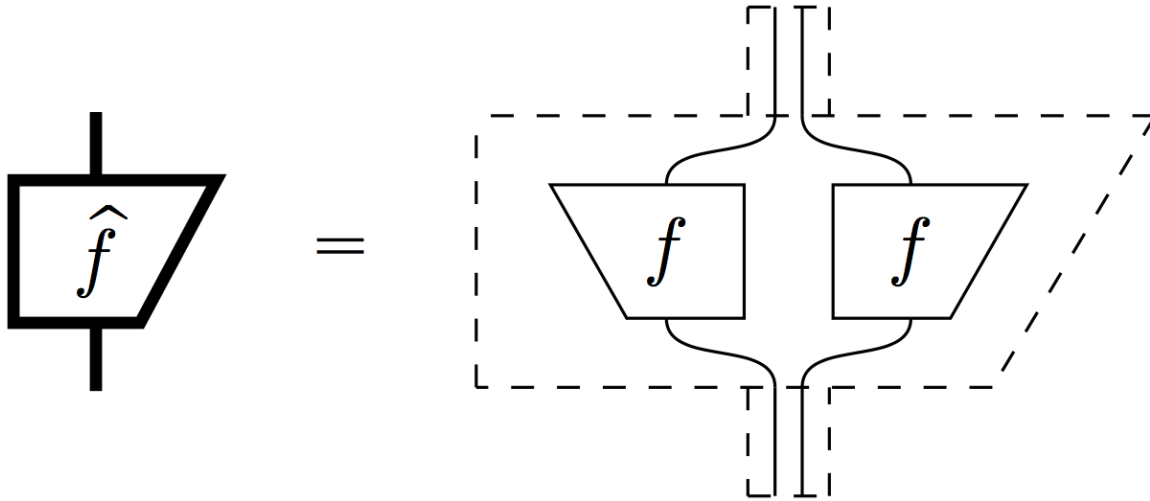

Born-rule ::=

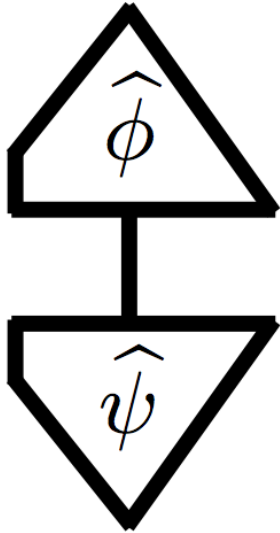

::=

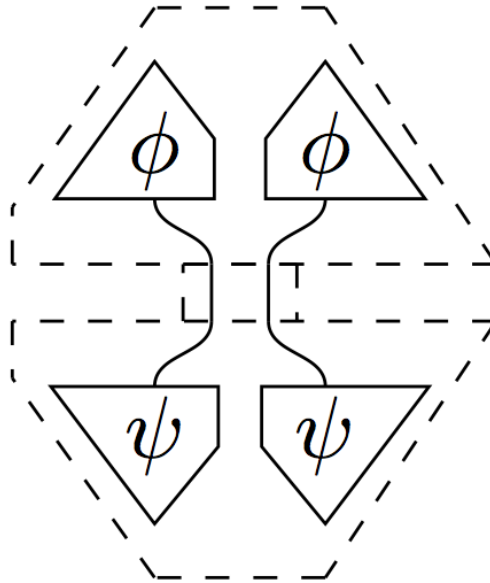

::=

Discarding :=

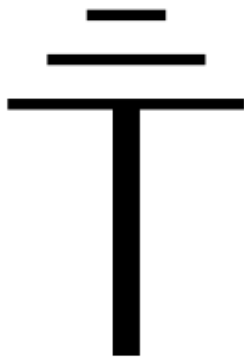

:=

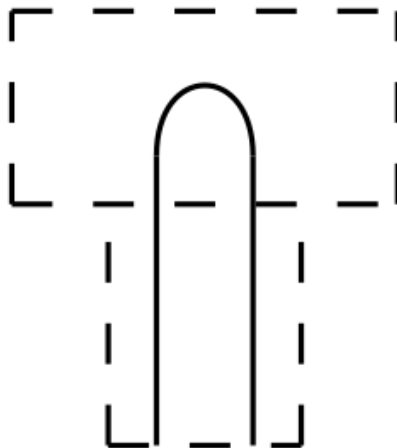

General quantum process :=

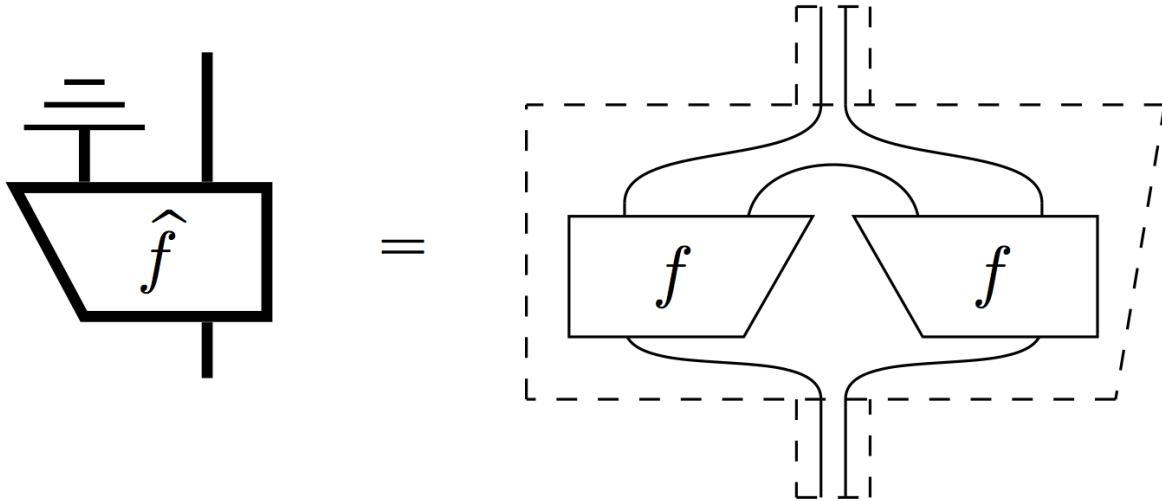

THM. No universal broadcasting

THM. No universal broadcasting i.e. no Δ s.t.:

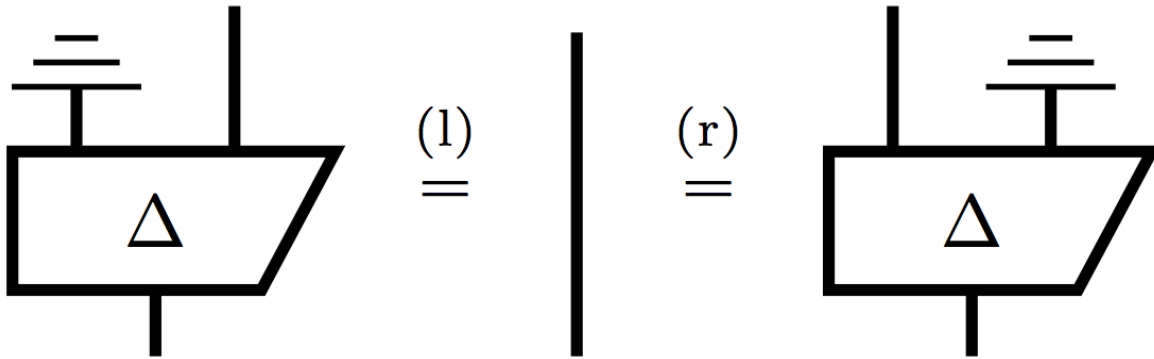

THM. No universal broadcasting i.e. no Δ s.t.:

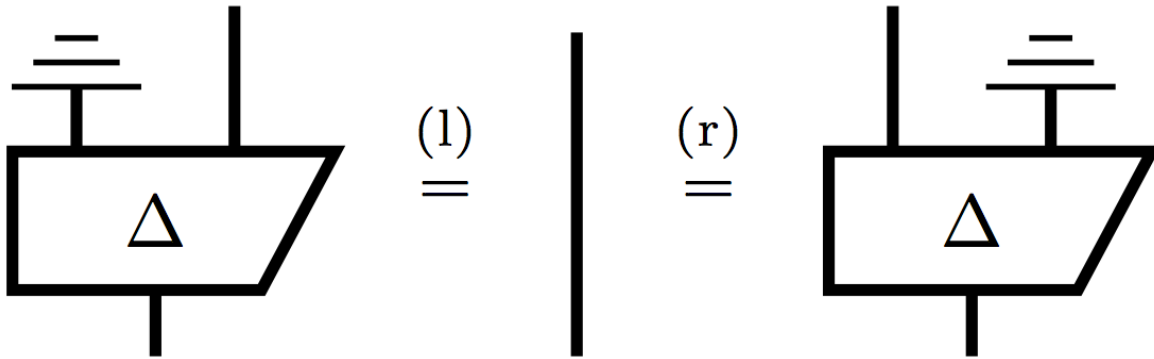

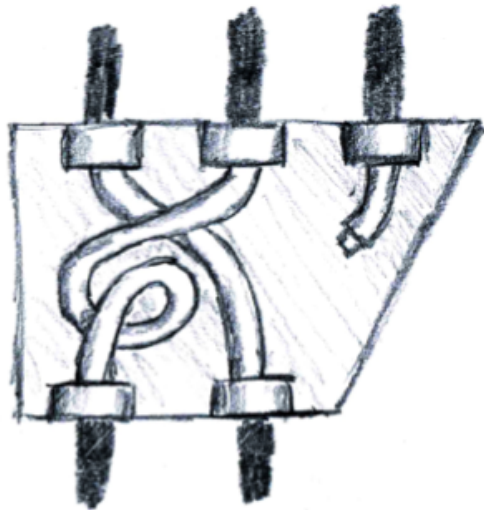

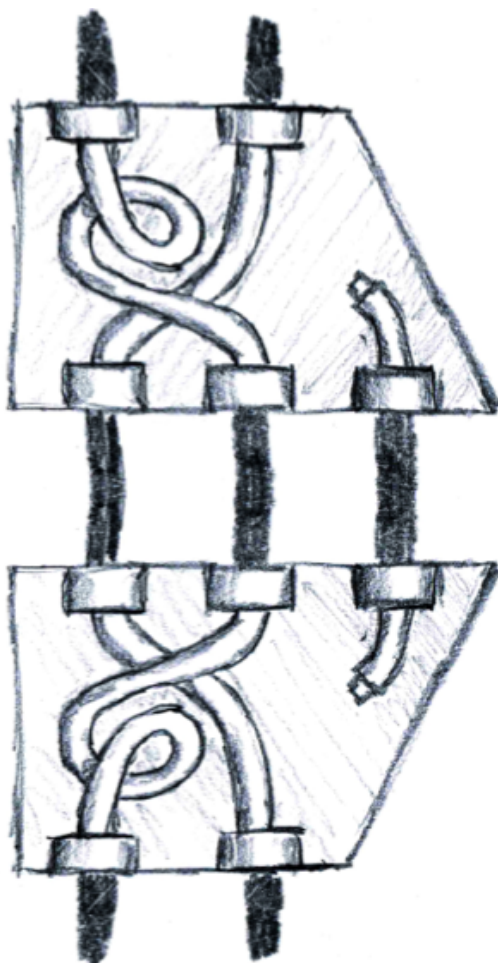

$$\left(\exists \psi, \phi : \begin{array}{c} \text{---} \\ | \\ \text{---} \end{array} \begin{array}{c} \diagup \\ f \\ \diagdown \end{array} \begin{array}{c} \text{---} \\ | \\ \text{---} \end{array} = \begin{array}{c} \text{---} \\ | \\ \text{---} \end{array} \begin{array}{c} \nabla \\ \phi \\ \nabla \end{array} \begin{array}{c} \text{---} \\ | \\ \text{---} \end{array} = \begin{array}{c} \text{---} \\ | \\ \text{---} \end{array} \begin{array}{c} \nabla \\ \psi \\ \nabla \end{array} \right) \iff \left(\exists \psi', \phi' : \begin{array}{c} \text{---} \\ | \\ \text{---} \end{array} \begin{array}{c} \nabla \\ f \\ \nabla \end{array} \begin{array}{c} \text{---} \\ | \\ \text{---} \end{array} \begin{array}{c} \diagup \\ f \\ \diagdown \end{array} \begin{array}{c} \text{---} \\ | \\ \text{---} \end{array} = \begin{array}{c} \text{---} \\ | \\ \text{---} \end{array} \begin{array}{c} \nabla \\ \phi' \\ \nabla \end{array} \begin{array}{c} \text{---} \\ | \\ \text{---} \end{array} = \begin{array}{c} \text{---} \\ | \\ \text{---} \end{array} \begin{array}{c} \nabla \\ \psi' \\ \nabla \end{array} \right)$$

Prop. Pure reduced state:

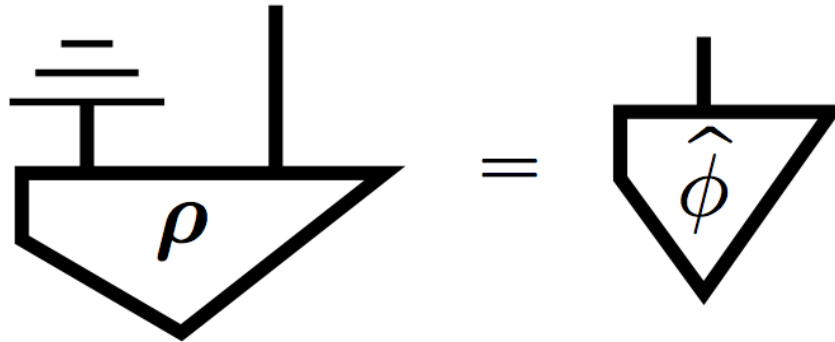

implies separation:

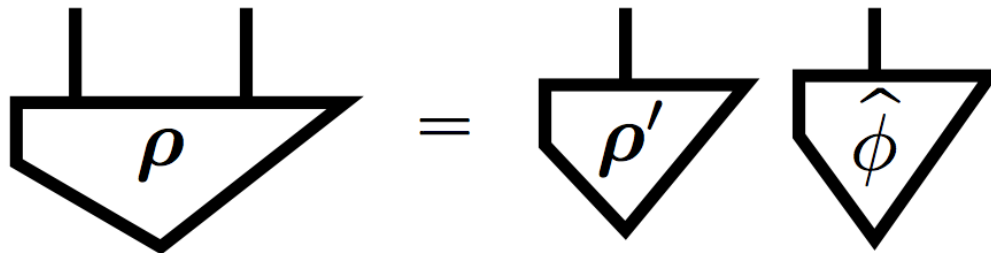

Pf. Since:

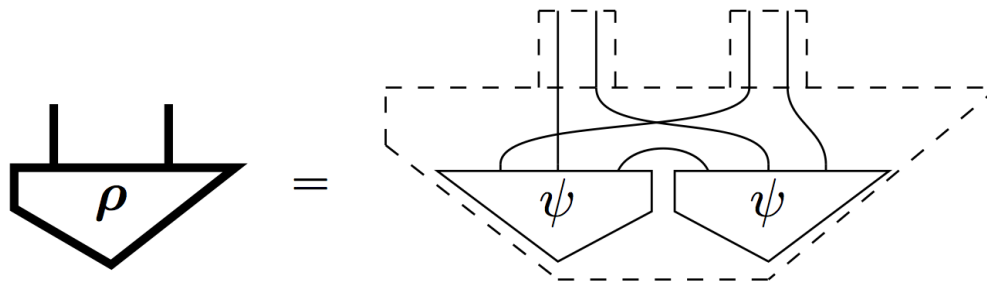

Pf. Since:

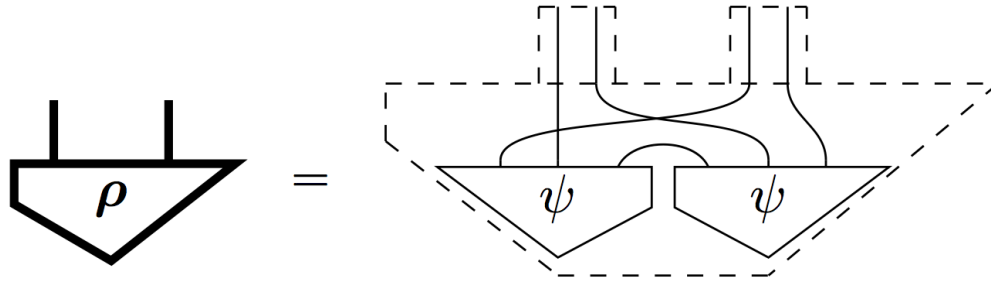

we have:

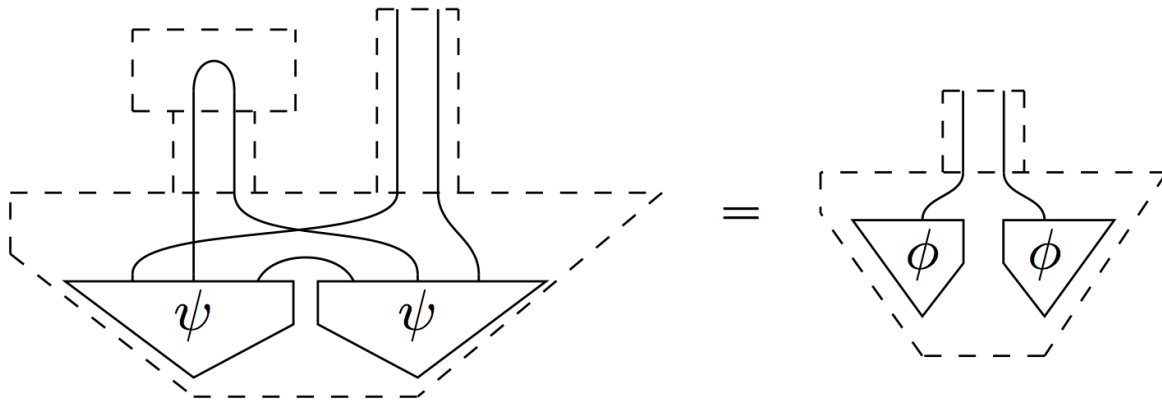

i.e.:

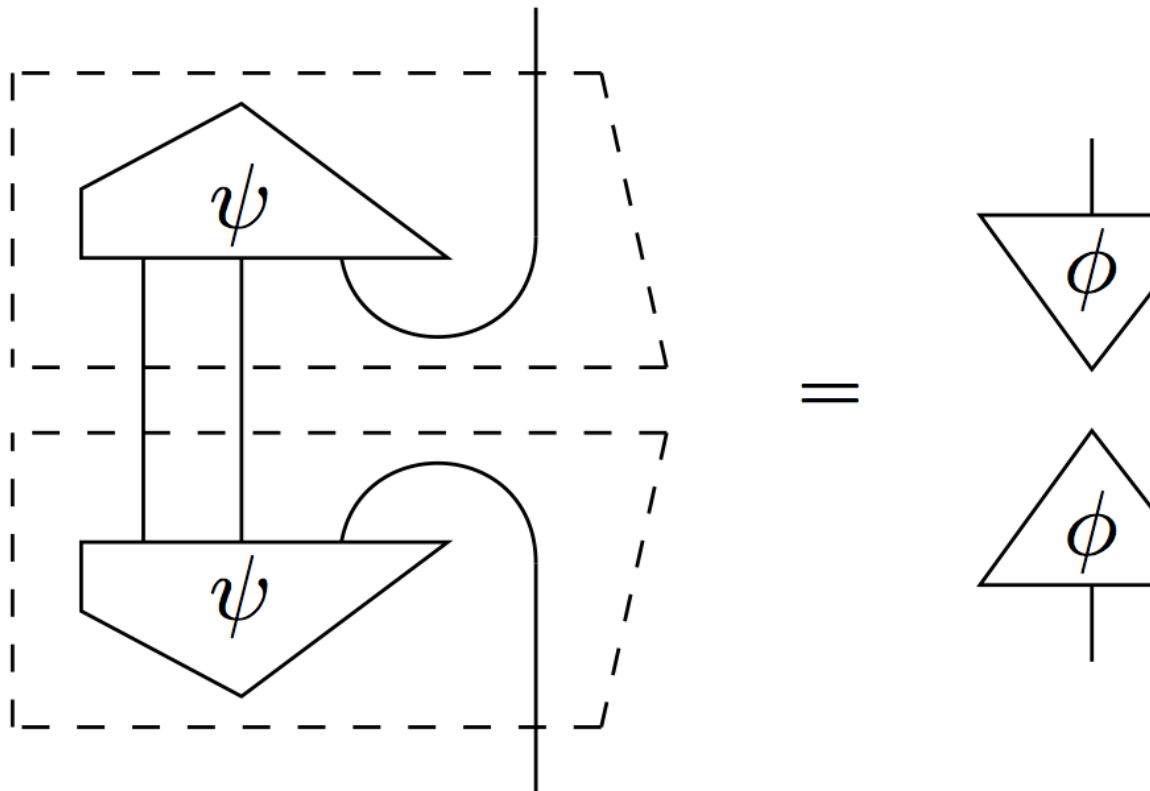

so:

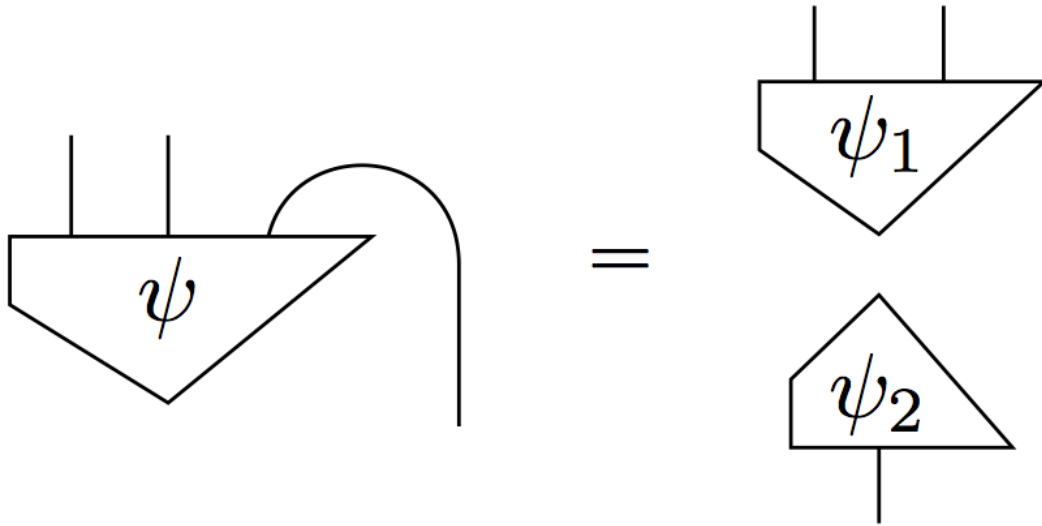

and hence:

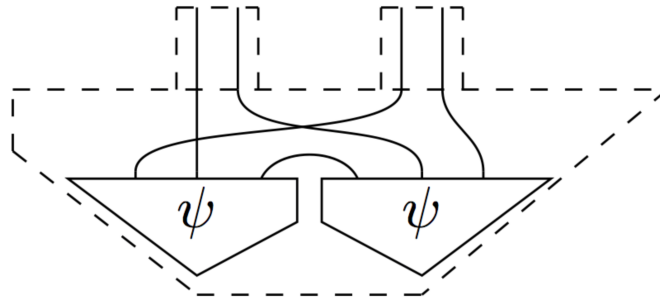

separates:

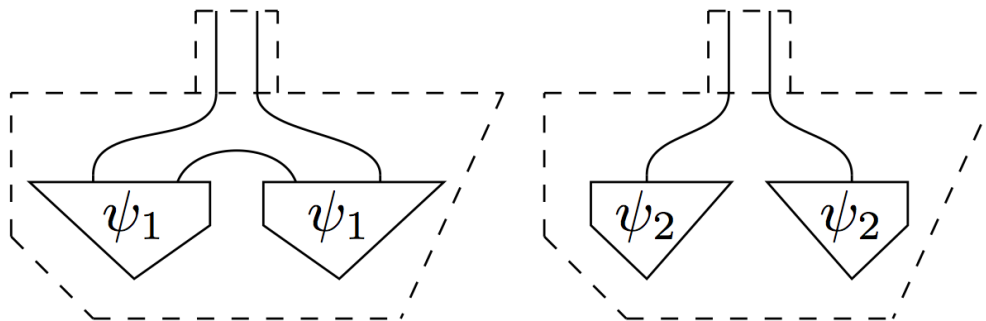

Prop. Pure reduced state:

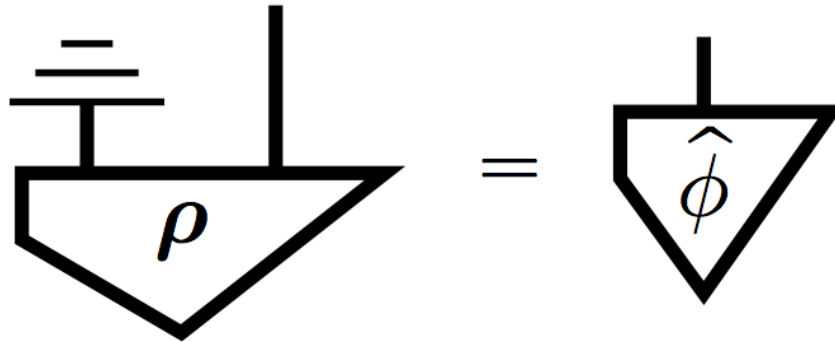

implies separation:

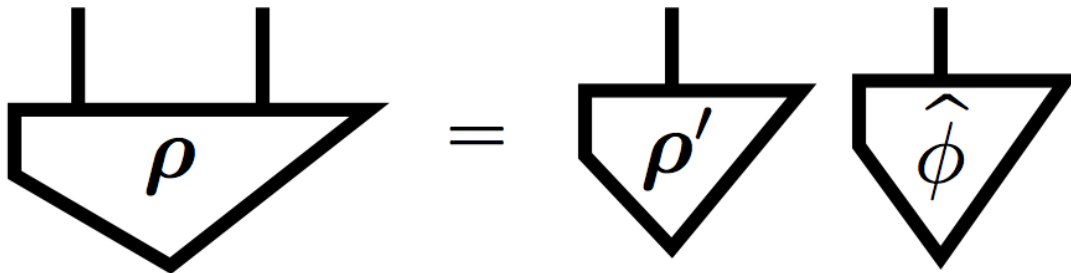

Prop. Pure reduced process:

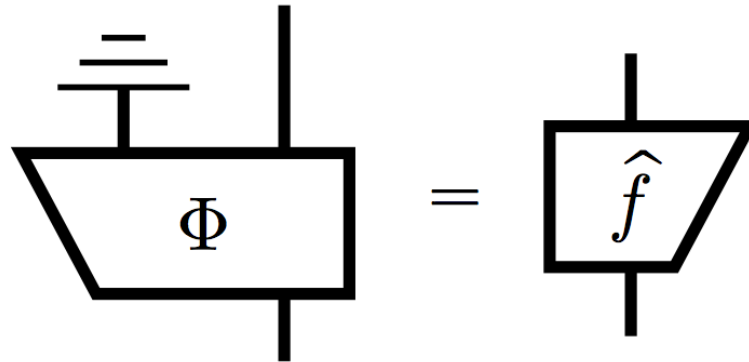

implies separation:

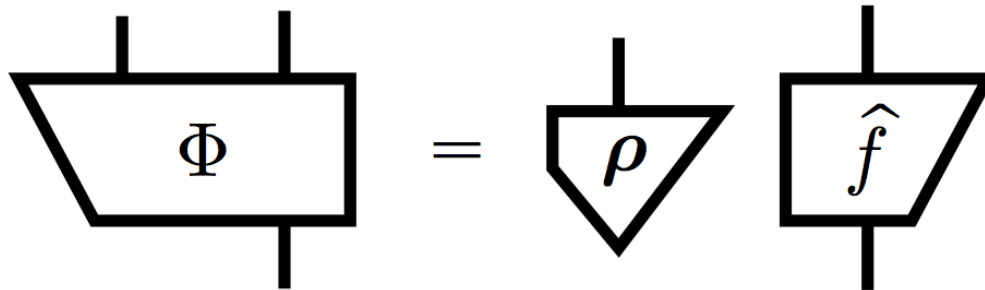

Pf. Reduces to previous:

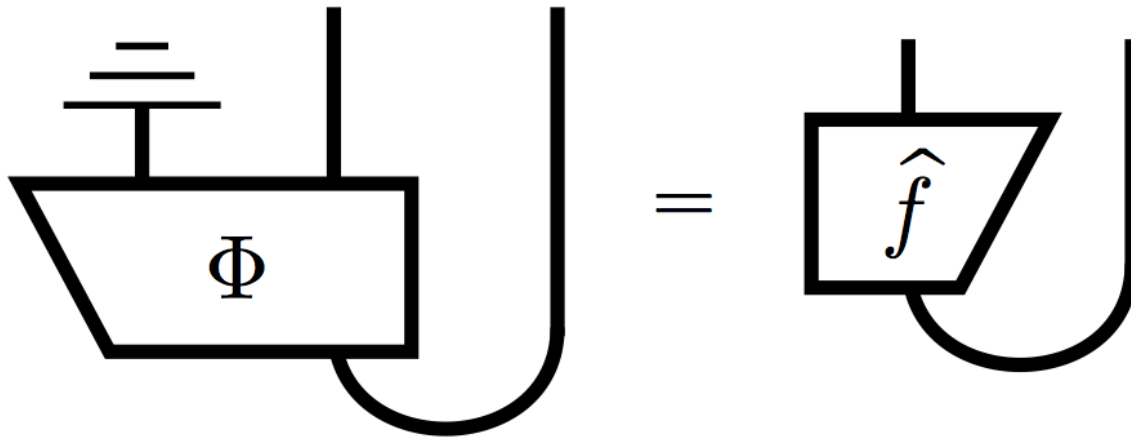

THM. No universal broadcasting i.e. no Δ s.t.:

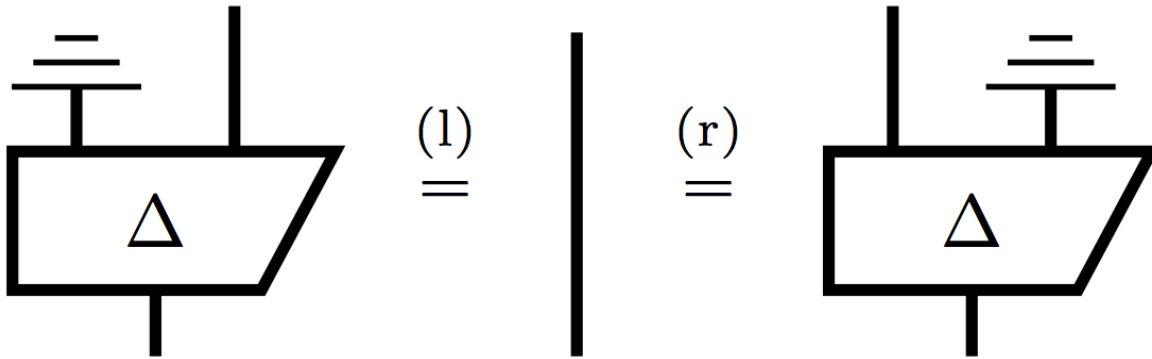

Pf. By (1) and Prop:

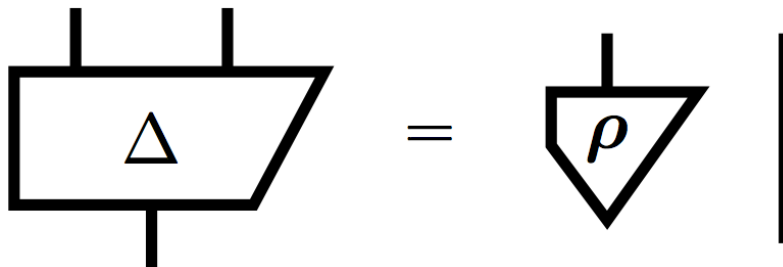

Pf. By (1) and Prop:

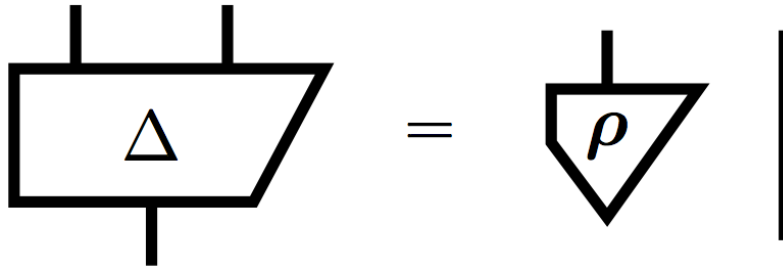

so:

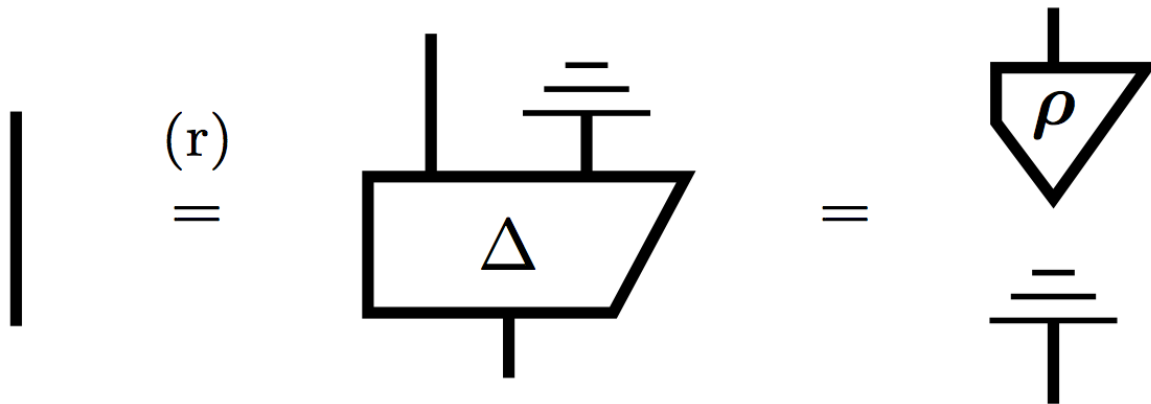

RIP

(3/3/2009 – 6/6/2016)

